



### Descriptions

The 2 channel power amplifiers are designed for commercial and industrial public address applications. With two separate amplifier in a single chassis and rated power ranges from 60W, 120W, 240W, 350W to 500W per channel which provides a wide selection to meet different size sound system needs. The amplifier is design of rack mount type and T-2S60/T-2S120 are in 2U height while T-2S240/T-2S350/T-2S500 are in 3U height.

Both balanced and unbalanced line inputs for each channel make it selectable for installer, balanced line outputs for each channel feed to another power amplifier as well as secure the signal transmission is less noise and longer distance. 70V, 100V and 4-16ohm speaker outputs for each channel are convenient for installation when selection different speaker matching. Master volume controls for each control are included. Complete protection includes over heat, over load, clip & short circuit. Indications for power, signal, clip, protection and temp.

### Features

- \* 2 separate amplifier into one chassis
- \* Rack mount amplifier in 2U (T-2S60/T-2S120) and 3U (T-2S240/T-2S350/T-2S500) types
- \* Rated power from 60W, 120W, 240W, 350W to 500W per channel
- \* 70V, 100V and 4-16ohm speaker outputs for each channel
- \* Isolated transformer for human safety operation
- \* Balanced XLR type line input and unbalanced 1/4 inch XLR phone jack line input for each Channel
- \* Balanced XLR type line outputs for each channel feed to another power amplifier
- \* Reliable protection of over heat, over load, clip & short circuit
- \* Indications for power, signal, clip, protection and temp
- \* Excellent device of radiator cooling fan that ensures working effectively

### Optional

- \* DC 24V input available on less than but not included 350W models

### Specifications

Model	T-2S350
Rated Power Output	2x350W
Speaker Outputs	70V, 100V & 4~16Ω
Input Sensitivity & Impedance	± 385mV/20KΩ, Balanced XLR Input 775mV/10KΩ, Unbalanced TRS Input
Output Sensitivity & Impedance	± 385mV/470Ω, Balanced XLR output 775mV/470Ω, Unbalanced TRS output
Overload Electromotive Force	> 15dB
Frequency Response	50Hz~16KHz(+1dB, -3dB)
S/N Ratio	> 90dB
THD	Less than 0.1% at 1KHz, 1/3 rated power
Crosstalk	< 50dB
Cooling	Fan automatically start up when temp reaches 55℃
Protection	Over heat, over load, clip & short circuit
Power Supply	~110V/60Hz or ~230V/50Hz or DC 24V
Power Consumption	1000W
Weight	25.3 Kg
Dimensions	484x359x132mm
Finish	Panel: aluminum plate, black Case: Steel plate, black

3U Rear Panel T-2S350

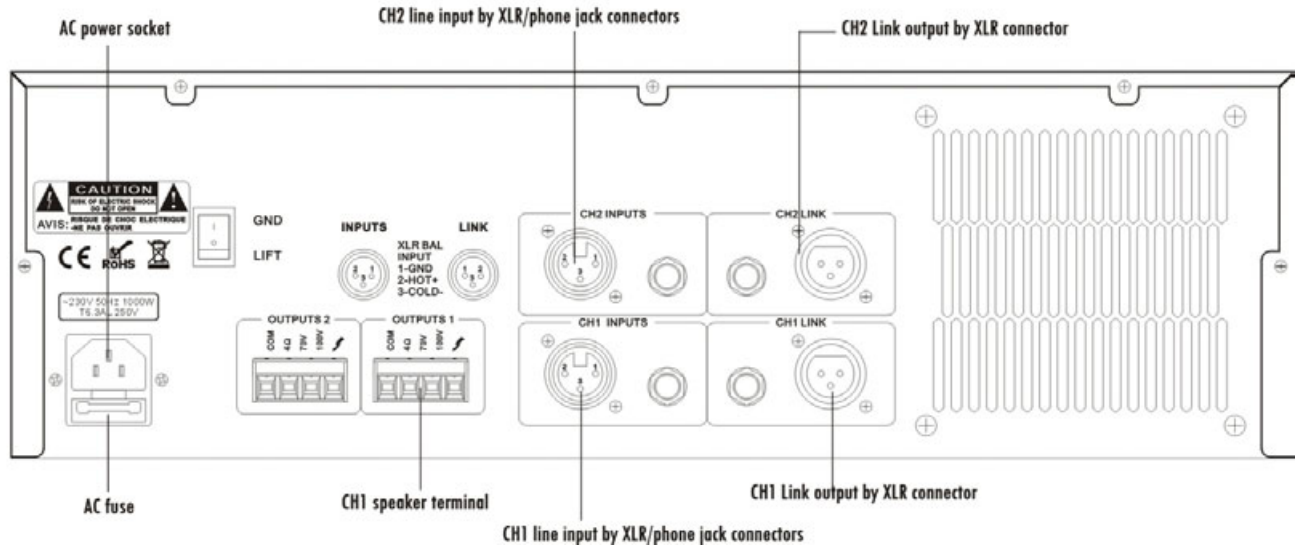

Connections

